

ECN/PCN No.: M1206

For Manufacturer			
Product Description: Axial Power Inductor	Abracon Part Number / Part Series: AIAP-02	<input type="checkbox"/> Documentation only <input checked="" type="checkbox"/> ECN <input checked="" type="checkbox"/> EOL	<input checked="" type="checkbox"/> Series <input type="checkbox"/> Part Number(s)
Affected Revision: E	New Revision: F	Application:	<input type="checkbox"/> Safety <input checked="" type="checkbox"/> Non-Safety

Prior to Change:

1.0 Key Electrical Specifications

Part No.	L(μH)	Tolerance (K: ±10%)	DCR(Ω) max	I _{DC} (A) max	Inductance Code
AIAP-02-3R9	3.9	K	0.019	7.3	3R9K
AIAP-02-4R7	4.7	K	0.022	6.3	4R7K
AIAP-02-5R6	5.6	K	0.024	5.6	5R6K
AIAP-02-6R8	6.8	K	0.026	5.3	6R8K
AIAP-02-8R2	8.2	K	0.028	4.5	8R2K
AIAP-02-100	10	K	0.033	4.1	100K
AIAP-02-120	12	K	0.037	3.6	120K
AIAP-02-150	15	K	0.040	3.3	150K
AIAP-02-180	18	K	0.044	3.0	180K
AIAP-02-220	22	K	0.050	2.7	220K
AIAP-02-270	27	K	0.056	2.5	270K
AIAP-02-330	33	K	0.076	2.2	330K
AIAP-02-390	39	K	0.094	2.0	390K
AIAP-02-470	47	K	0.109	1.8	470K
AIAP-02-560	56	K	0.131	1.7	560K
AIAP-02-680	68	K	0.142	1.5	680K
AIAP-02-820	82	K	0.152	1.4	820K
AIAP-02-101	100	K	0.208	1.2	101K
AIAP-02-121	120	K	0.283	1.1	121K
AIAP-02-151	150	K	0.340	1.0	151K
AIAP-02-181	180	K	0.362	0.95	181K
AIAP-02-221	220	K	0.430	0.86	221K
AIAP-02-271	270	K	0.557	0.77	271K
AIAP-02-331	330	K	0.655	0.70	331K
AIAP-02-391	390	K	0.772	0.64	391K
AIAP-02-471	470	K	1.150	0.59	471K
AIAP-02-561	560	K	1.27	0.54	561K
AIAP-02-681	680	K	1.61	0.49	681K
AIAP-02-821	820	K	1.96	0.44	821K
AIAP-02-102	1000	K	2.30	0.40	102K
AIAP-02-122	1200	K	2.65	0.35	122K
AIAP-02-152	1500	K	3.45	0.33	152K
AIAP-02-182	1800	K	4.03	0.29	182K
AIAP-02-222	2200	K	4.48	0.27	222K
AIAP-02-272	2700	K	5.40	0.24	272K
AIAP-02-332	3300	K	6.56	0.22	332K
AIAP-02-392	3900	K	8.63	0.20	392K
AIAP-02-472	4700	K	9.66	0.18	472K
AIAP-02-562	5600	K	13.9	0.17	562K
AIAP-02-682	6800	K	16.3	0.15	682K
AIAP-02-822	8200	K	20.8	0.14	822K
AIAP-02-103	10000	K	26.4	0.14	102K
AIAP-02-123	12000	K	29.9	0.11	123K
AIAP-02-153	15000	K	42.5	0.10	153K
AIAP-02-183	18000	K	48.3	0.09	183K

Table #1

1.1 Test Conditions and equipments

Test frequency: 1kHz, 0.1Vrms
 I_{DC}: 10% inductance drops typical

1.2 Operating Temperature

-40°C ~ +85 °C

1.3 Storage Temperature

-40°C ~ +85 °C

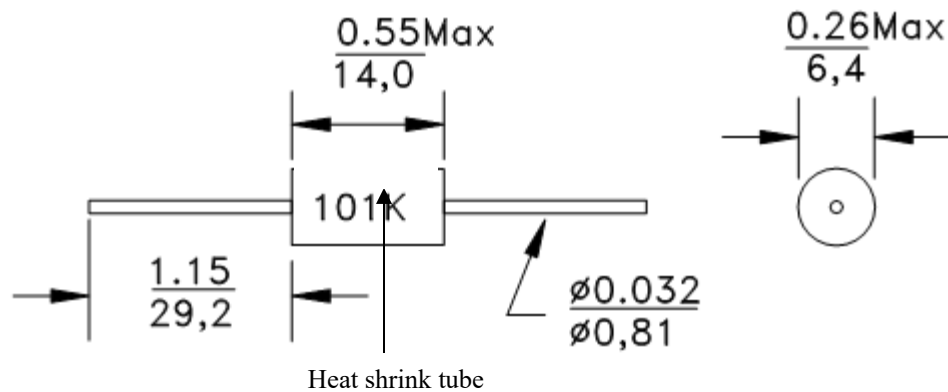
2.0 Mechanical Dimensions

2.0 Packing (100pcs / bag)
After Change:
2.0 Key Electrical Specifications

Part No.	L(μH)	Tolerance	DCR(Ω) max	I _{DC} (A) max	Inductance Code
AIAP-02-3R9	3.9	M	0.019	7.3	3R9M
AIAP-02-4R7	4.7	M	0.022	6.3	4R7M
AIAP-02-5R6	5.6	M	0.024	5.6	5R6M
AIAP-02-6R8	6.8	M	0.026	5.3	6R8M
AIAP-02-8R2	8.2	K	0.028	4.5	8R2K
AIAP-02-100	10	K	0.033	4.1	100K
AIAP-02-120	12	K	0.037	3.6	120K
AIAP-02-150	15	K	0.040	3.3	150K

AIAP-02-180	18	K	0.044	3.0	180K
AIAP-02-220	22	K	0.050	2.7	220K
AIAP-02-270	27	K	0.056	2.5	270K
AIAP-02-330	33	K	0.076	2.2	330K
AIAP-02-390	39	K	0.094	2.0	390K
AIAP-02-470	47	K	0.109	1.8	470K
AIAP-02-560	56	K	0.131	1.7	560K
AIAP-02-680	68	K	0.142	1.5	680K
AIAP-02-820	82	K	0.152	1.4	820K
AIAP-02-101	100	K	0.208	1.2	101K
AIAP-02-121	120	K	0.283	1.1	121K
AIAP-02-151	150	K	0.340	1.0	151K
AIAP-02-181	180	K	0.362	0.95	181K
AIAP-02-221	220	K	0.430	0.86	221K
AIAP-02-271	270	K	0.557	0.77	271K
AIAP-02-331	330	K	0.655	0.70	331K
AIAP-02-391	390	K	0.772	0.64	391K
AIAP-02-471	470	K	1.150	0.59	471K
AIAP-02-561	560	K	1.27	0.54	561K
AIAP-02-681	680	K	1.61	0.49	681K
AIAP-02-821	820	K	1.96	0.44	821K
AIAP-02-102	1000	K	2.30	0.40	102K
AIAP-02-122	1200	K	2.65	0.35	122K
AIAP-02-152	1500	K	3.45	0.33	152K
AIAP-02-182	1800	K	4.03	0.29	182K
AIAP-02-222	2200	K	4.48	0.27	222K
AIAP-02-272	2700	K	5.40	0.24	272K
AIAP-02-332	3300	K	6.56	0.22	332K
AIAP-02-392	3900	K	8.63	0.20	392K
AIAP-02-472	4700	K	9.66	0.18	472K
AIAP-02-562	5600	K	13.9	0.17	562K
AIAP-02-682	6800	K	16.3	0.15	682K
AIAP-02-822	8200	K	20.8	0.14	822K
AIAP-02-103	10000	K	26.4	0.14	102K
AIAP-02-123	12000	K	29.9	0.11	123K
AIAP-02-153	15000	K	42.5	0.10	153K
AIAP-02-183	18000	K	48.3	0.09	183K

Table #1
2.1 Test Conditions and equipments

Test frequency: 1kHz, 0.25V_{rms}
 I_{DC}: 10% inductance drops typical

1.4 Tolerance Codes

M: ±20%, K: ±10%

1.5 Operating Temperature

-40°C ~ +125°C (Including Self-heating)

1.6 Storage Temperature

-40°C ~ +125°C

3.0 Mechanical Dimensions

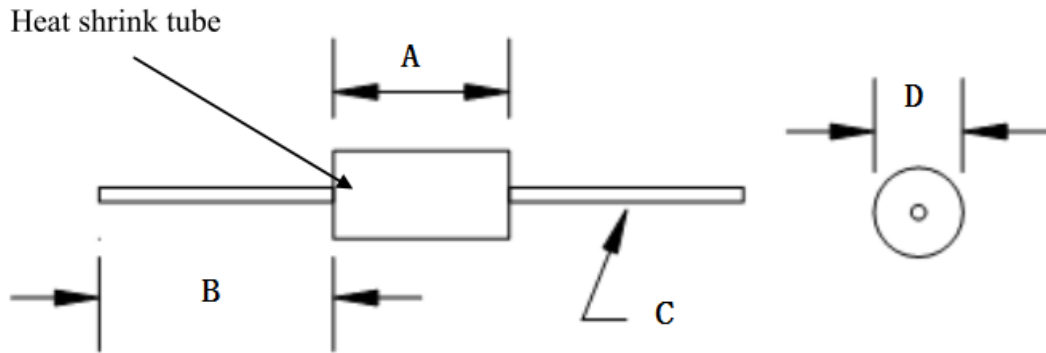

A	B	C	D
14.0 MAX	29.2 ±2	0.6	6.4 MAX

Dimension: mm

3.0 Packing (500pcs / bag)

Cause/Reason for Change: Moving the series to a new production line,
 Relaxed tolerance on some parts
 AIAP-02-3R9
 AIAP-02-4R7
 AIAP-02-5R6
 AIAP-02-6R8
 change in operating temperature range, testing conditions, graphics, PCS/bag

Change Plan

Effective Date:
 12/3/2020

Additional Remarks:

Change Declaration:The change does not affect form fit of the series.The update includes: Wider operating temperature, update to the testing conditions,graphics ,pcs/bag.
 The tolerance was relaxed on the following parts:
 AIAP-02-3R9

AIAP-02-4R7 AIAP-02-5R6 AIAP-02-6R8		
Issued Date: 12/3/2020	Issued By: Ahmed Alamin	Issued Department: Engineering
Approval: Syed Raza Engineering VP	Approval: Reuben Quintanilla Quality Director	Approval: Ying Huang Purchasing Director
For Abracon EOL only		
Last Time Buy (if applicable):		Alternate Part Number / Part Series:
Additional Approval:	Additional Approval:	Additional Approval:
Customer Approval (If Applicable)		
Qualification Status: <div style="text-align: center;"> <input type="checkbox"/> Approved <input type="checkbox"/> Not accepted </div> <i>Note: It is considered approved if there is no feedback from the customer 1 month after ECN/PCN is released.</i>		
Customer Part Number:		Customer Project:
Company Name:	Company Representative:	Representative Signature:
Customer Remarks:		